



PRODUCT SELECTION DATA

HEAT PUMPS AND LIQUID COOLERS WITH WATER COOLED CONDENSER



- Cooling and heating application
- High energy efficiency
- Compact design
- Low sound level
- Broad field of application

30WI 700 V - 2400 V



Cooling capacity: 200-700 kW
Heating capacity: 230-800 kW

The new generation of AQUASNAP 30WI water cooled heat pumps and water chillers offers an optimal solution for all heating process or cooling applications.

These units are designed to be installed in machine rooms that are protected against freezing temperatures and inclement weather.

The new range has been optimised to use ozone-friendly HFC R410A refrigerant. The use of this refrigerant guarantees compliance with the most demanding requirements for environmental protection and increased seasonal energy efficiency.



CARRIER participates in the ECP programme for LCP/HP
Check ongoing validity of certificate:
www.eurovent-certification.com

RANGE

AQUASNAP 30WI

Cooling-only or heating-only models with water-cooled condenser.

Acoustic configuration:

- a - STANDARD version
- b - LOW NOISE version. Compressor casing
- c - VERY LOW NOISE version. Casing with compressor sound insulation

DESCRIPTION

AQUASNAP series 30WI units are packaged machines supplied as standard with the following components:

- SCROLL hermetic compressors,
- Chilled water evaporator with brazed plates,
- Hot water condenser with brazed plates,
- Electrical power and remote control cabinet:
 - 400V-3ph-50Hz general electrical power supply (+10%/-10%) + earth,
 - Transformer fitted as standard on the machine for supplying the remote control circuit with 230V-1ph-50Hz,
- 30WI Control electronic control module.

The AQUASNAP 30WI range complies with the following European standards and directives:

- Machinery directive 2006/42/EC.
- Electromagnetic compatibility directive 2004/108/EC.
- EMC immunity and emissions EN 61800-3 'C3'
- Low voltage directive 2006/95/EC.
- RoHS 2011/65/EU
- Pressure equipment directive (PED) 97/23/EC
- Machinery directive EN 60-204 -1

DESCRIPTION OF THE MAIN COMPONENTS

■ Compressors

- Hermetic SCROLL type.
- Built-in electric motor cooled by intake gases.
- Motor protected by internal winding thermostat.
- Placed on anti-vibration mounts.

■ Evaporator

- Brazed plate exchanger.
- Stainless steel plates (AISI 316).
- Plate patterns optimised for high efficiency.
- Armaflex thermal insulation.

■ Condenser

- Brazed plate exchanger.
- Stainless steel plates (AISI 316).
- Plate patterns optimised for high efficiency.

■ Refrigerating accessories

- Dehumidifier filters with rechargeable cartridges.
- Hygroscopic sight glasses.
- Solenoid valves on refrigerant lines (700 V to 1200 V models).
- Electronic expansion valves.

■ Control and safety instruments

- High and low pressure sensors.
- High pressure safety valves.
- Water temperature control sensors.
- Evaporator frost protection sensor.
- Factory-assembled evaporator water flow controller.

■ Electrical box

- IP 23.
- 400V-3Ph-50 Hz power supply + Earth (+10%/-10%).
- Main safety switch with handle on front.
- Control circuit transformer.
- Circuit breaker for compressor motor.
- Compressor motor switches.
- 30WI Control microprocessor-controlled electronic control module.
- Wire numbering.
- Marking of the main electrical components.
- RAL 7035.

■ 30WI Control electronic control module.

The electronic control module performs the following main functions:

- Regulation of the chilled or hot water temperature
- Regulation of the water temperature based on the outdoor temperature (water law).
- Regulation for low temperature energy storage.
- Second setpoint management.
- Complete management of compressors with start-up sequence, metering and runtime balancing.
- Self-adjusting and proactive functions with adjustment of parameters on drift control.
- In-series staged capacity-reduction system on compressors based on cooling and heating demands.
- Management of compressor short cycle protection.
- Management of the machine operation limit according to outdoor temperature.
- Operating and fault status diagnostics.
- Management of a fault memory allowing a log of the last 20 incidents to be accessed, with operating readings taken when the fault occurs.
- Master/slave management of the two machines in parallel with runtime balancing and automatic changeover if a fault occurs on one machine.
- Machine time schedule.
- Display and access to the operating parameters via a multilingual LCD screen with 4 lines of 24 characters.

■ Remote management

30WI Control is equipped as standard with an RS485 serial port offering a range of remote management, monitoring and diagnostic options via the communication bus.

Several contacts are available as standard, enabling the AQUASNAP 30WI to be controlled remotely by wired link:

- Automatic operation control: when this contact is open, the machine stops.
- Setpoint 1/setpoint 2 selector: when this contact is closed, a second cooling setpoint is activated (energy storage mode, for example).
- Heating/cooling mode selector: this input switches from one operating mode to another. Contact closed = heating mode.

Contact open = cooling mode.

- Setpoint adjustable via 4-20 mA signal: this input is used to adjust the setpoint in heating or cooling mode.
- Compressor load shedding: closing the contact(s) concerned allows the power or refrigerating consumption of the machine to be limited by stopping one or more compressors.
- Water pump 1 and 2 control: these outputs control the switches for one or two water pumps.
- Fault reporting: this contact indicates the presence of a major fault which has caused one or both refrigerating circuits to stop.

■ Capacity control

In-series staged power control system on the compressors:

- 4 stages for 700 V to 1600 V models.
- 6 stages for 1800 V and 2400 V models.
- 8 stages for 2100 V models.

■ Casing

Casing made from RAL 7035 painted panels.

OPTIONS

Options	No.	Description	Advantages	Use
Soft Starter	25	Electronic starter on each compressor	Reduced start-up current	0700-2400
Master/slave operation	58	Unit equipped with supplementary water outlet temperature sensor kit to be fieldinstalled allowing master/slave operation of two units connected in parallel	Optimised operation of two units connected in parrallele operation with operating time equalisation	0700-2400
Condenser insulation	86	Thermal condenser insulation	Minimizes thermal dispersions condenser side (key option for heat pump or heat recovery applications) and allows compliancy with special installation criteria (hot parts insulated)	0700-2400
Compressor suction valve	92	Valve installed on the compressor suction side to isolate it in the refrigerant circuit	Simplified service and maintenance	0700-2400
Lon gateway	148D	Two-directional communication board complying with Lon Talk protocol	Connects the unit by communication bus to a building management system	0700-2400
Bacnet over IP	149	Two-directional high-speed communication using BACnet protocol over Ethernet network (IP)	Easy and high-speed connection by ethernet line to a building management system. Allows access to multiple unit parameters	0700-2400
Dry contact board	156C	Feedback board on the potential-free contact for the main statuses and faults	Simple feedback of the diagnostics and unit state	0700-2400
Phase controller	159B	Phase controller on the power	Reinforced protection of the compressors by monitoring rotation, the absence and asymmetry of the phases, and the over- or under-voltage of the electricity network	0700-2400
Compliance with Russian regulations	199	EAC certification	Conformance with Russian regulations	0700-2400
Low noise level	257	Compressor sound enclosure	Reduced sound emissions	0700-2400
Very low sound level	258	Enhanced sound insulation of main noise sources (Material classified CD0S2 fire class according to Euroclass 13-501).	6 dB(A) quieter than standard . Refer to the physical data table for detailed values	0700-2400
Welded evaporator connection kit	266	Victaulic piping connections with welded joints	Easy installation	0700-2400
Welded condenser water connection kit	267	Victaulic piping connections with welded joints	Easy installation	0700-2400
Electric energy meter	294	MID certified electric energy meter (compliant with directive 2004/22/EC). Display of energy consumption, instantaneous (U, V, I) and cumulative (kWh), on the SmartVu™ interface	Permits the acquisition, (remote) monitoring and billing of energy used.	0700-2400
External temperature sensor	312	External temperature sensor control for using weather compensation	Allow to adjust set point using weather compensation and define autorisation operation mode to external temperature	0700-2400
Compliance with Morocco regulation	327	Specifics documents according Morroco regulation	Conformance with Morocco regulations	0700-2400

TECHNICAL SPECIFICATIONS

30WI		700 V	800 V	900 V	1000 V	1100 V	1200 V		
Heating									
Standard unit Seasonal energy efficiency**	HA1	SCOP _{30/35°C}	kW / kW	5,30	5,53	5,45	5,47	5,43	5,49
		ηs heat _{30/35°C}	%	204	213	210	211	209	212
		P _{rated}	kW	246	293	335	384	419	463
Cooling									
Standard unit Full load performances*	CA1	Net cooling capacity	kW	203	242	278	320	348	382
		Net power input	kW	49	56	64	71	79	86
		EER	kW / kW	4,18	4,32	4,33	4,5	4,42	4,42
Standard unit Seasonal energy efficiency**		SEPR _{-2/-8°C} Process medium temp ***	kWh/kWh	3,04	3,08	3,09	3,04	3,08	3,11
Standard unit Seasonal energy efficiency**		SEER _{12/7°C} Comfort Low temp.	kW / kW	4,66	4,96	4,92	4,96	4,91	4,92
Standard unit		Lw / Lp ⁽¹⁾	dB(A)	89/57	90/58	90/58	89/57	90/58	91/59
Unit + Low Noise option		Lw / Lp ⁽¹⁾	dB(A)	84/52	85/53	85/53	86/54	87/55	88/56
Unit + Xtra Low Noise		Lw / Lp ⁽¹⁾	dB(A)	79/47	80/48	80/48	80/48	81/49	82/50
Refrigerating circuit									
Refrigerant (GWP)	R410 (GWP=2088)								
Number	2								
Refrigerant circuit 1	kg	13,5	15,5	16,4	17	19,7	21,3		
Refrigerant circuit 2	kg	14	15	16,4	17,2	19,7	21,3		
Tonne of CO ₂ equivalent	TCO ₂ Eq	57,42	63,68	68,49	71,41	82,27	88,95		
Compressor									
Type	Hermetic scroll (- 2900 rpm)								
Number	4	4	4	4	4	4	4		
Start-up mode	Direct in line in series								
	Number of stages	6	4	6	4	6	4		
Capacity control	%	100-78-71-50-28-21-0	100-75-50-25-0	100-78-71-50-28-21-0	100-75-50-25-0	100-78-71-50-28-21-0	100-75-50-25-0		
Type of oil for R410A	Polyolester POE								
Oil load per circuit	l	6,7+6,7	6,7+6,7	6,7+6,7	6,7+6,7	6,7+7,2	7,2+7,2		
Evaporator									
Type/ Number	Braze-plate heat exchanger/1								
Water capacity	l	20	23	26	29	32	37		
Victaulic connection	Ø	DN100	DN100	DN100	DN125	DN125	DN125		
Max. pressure, water end	bar	10 bar							
Min/max water flow	m ³ /h	22/70	26/81	29/92	33/105	35/113	38/124		
Water-cooled condenser									
Type/ Number	Braze-plate heat exchanger/1								
Water capacity	l	23	26	29	32	37	40		
Victaulic connection	Ø	DN100	DN100	DN100	DN125	DN125	DN125		
Max. pressure, water end	bar	10 bar							
Min/max water flow	m ³ /h	19/64	22/74	25/84	28/95	31/103	33/112		
Dimensions									
Length	mm	2099	2099	2099	2099	2099	2099		
Width	mm	996							
Height	mm	1869	1869	1869	1869	1869	1869		
Weight									
Weight (empty)	kg	1044	1156	1189	1312	1363	1425		
Weight in operation	kg	1088	1205	1246	1378	1436	1510		
Max. storage temperature	°C	+50°C							

Outputs in accordance with EUROVENT standard EN 14511 conditions

* In accordance with standard EN14511-3:2022.

** In accordance with standard EN14825:2022, average climate

*** With EG 30%.

HA1 Heating mode conditions: Water heat exchanger water entering/leaving temperature 30°C/35°C, outside air temperature tdb/twb = 7°C db/6°C wb, evaporator fouling factor 0 m². kW.

CA1 Cooling mode conditions: evaporator water inlet/outlet temperature 12 °C/7 °C, outdoor air temperature 35 °C, evaporator fouling factor 0 m². kW

ηs heat_{30/35°C} & SCOP_{30/35°C} Values in bold comply with Ecodesign Regulation (EU) No. 813/2013 for Heating applications.

SEER_{12/7°C} Values calculated according to EN14825:2022.

SEPR_{-2/-8°C} Values in bold comply with Ecodesign Regulation (EU) No. 2015/1095 for Process application

(1) Lw : overall power level in accordance with standard ISO3744

Lp : overall pressure level at 10 metres in a free field calculated using the formula Lp=LW-10logS



Eurovent certified values

TECHNICAL SPECIFICATIONS

30WI			1400 V	1600 V	1800 V	2100 V	2400 V	
Heating								
Standard unit Seasonal energy efficiency**	HA1	SCOP _{30/35°C}	kW / kW	5,49	5,48	5,44	5,46	5,24
		η _{s heat} _{30/35°C}	%	212	211	210	211	202
		P _{rated}	kW	530	593	687	795	876
Cooling								
Standard unit Full load performances*	CA1	Net cooling capacity	kW	439	495	574	651	703
		Net power input	kW	97	108	125	145	165
		EER	kW / kW	4,55	4,6	4,6	4,49	4,27
Standard unit Seasonal energy efficiency**		SEPR _{-2/-8°C} Process medium temp ***	kWh/kWh	3,21	3,31	3,26	3,33	3,37
Standard unit Seasonal energy efficiency**		SEER _{12/7°C} Comfort Low temp.	kW / kW	4,98	4,97	4,99	4,89	4,60
Standard unit		Lw / Lp ⁽¹⁾	dB(A)	95/63	96/64	93/61	95/63	97/65
Unit + Low Noise option		Lw / Lp ⁽¹⁾	dB(A)	90/58	91/59	89/57	90/58	91/59
Unit + Xtra Low Noise		Lw / Lp ⁽¹⁾	dB(A)	85/53	86/54	85/53	86/54	87/55
Refrigerating circuit								
Refrigerant (GWP)	R410 (GWP=2088)							
Number	2							
Refrigerant circuit 1	kg	21,5	23	31	33	34	34	
Refrigerant circuit 2	kg	21	22	31	34	34	34	
Tonne of CO ₂ equivalent	TCO ₂ Eq	88,74	93,96	129,46	139,9	141,98	141,98	
Compressor								
Type	Hermetic scroll (- 2900 rpm)							
Number	4							
Start-up mode	Direct in line in series							
Capacity control	Number of stages	6	4	6	8	6		
	%	100-78-71-50-28-21-0	100-75-50-25-0	100-83-66-50-33-16-0	100-84-66-48-36-30-18-15-0	100-83-66-50-33-16-0		
Type of oil for R410A	Polyolester POE							
Oil load per circuit	l	6,3+6,3	6,3+6,3	3x6,3	3x6,3	3x6,3	3x6,3	
Evaporator								
Type/ Number	Brazen-plate heat exchanger							
Water capacity	l	50	57	64	77	77	77	
Victaulic connection	Ø	DN125	DN125	DN150	DN150	DN150	DN150	
Max. pressure, water end	bar	10 bar						
Min/max water flow	m ³ /h	44/137	51/151	61/150	68/150	74/150	74/150	
Water-cooled condenser								
Type/ Number	Brazen-plate heat exchanger							
Water capacity	l	55	61	73	77	77	77	
Victaulic connection	Ø	DN125	DN125	DN150	DN150	DN150	DN150	
Max. pressure, water end	bar	10 bar						
Min/max water flow	m ³ /h	38/129	43/143	52/150	59/150	66/163	66/163	
Dimensions								
Length	mm	2499	2499	3350	3350	3350	3350	
Width	mm	996						
Height	mm	1887	1887	1970	1970	1970	1970	
Weight								
Weight (empty)	kg	1613	1708	2284	2376	2418	2418	
Weight in operation	kg	1713	1818	2472	2588	2637	2637	
Max. storage temperature	°C	+50°C						

Outputs in accordance with EUROVENT standard EN 14511 conditions

* In accordance with standard EN14511-3:2022.

** In accordance with standard EN14825:2022, average climate

*** With EG 30%.

HA1 Heating mode conditions: Water heat exchanger water entering/leaving temperature 30°C/35°C, outside air temperature tdb/twb = 7°C db/6°C wb, evaporator fouling factor 0 m². k/W.

CA1 Cooling mode conditions: evaporator water inlet/outlet temperature 12 °C/7 °C, outdoor air temperature 35 °C, evaporator fouling factor 0 m². k/W

η_{s heat}_{30/35°C} & SCOP_{30/35°C} Values in bold comply with Ecodesign Regulation (EU) No. 813/2013 for Heating applications.

SEER_{12/7°C} Values calculated according to EN14825:2022.

SEPR_{-2/-8°C} Values in bold comply with Ecodesign Regulation (EU) No. 2015/1095 for Process application

(1) Lw : overall power level in accordance with standard ISO3744

Lp : overall pressure level at 10 metres in a free field calculated using the formula Lp=LW-10logS



Eurovent certified values

ELECTRICAL SPECIFICATIONS

30WI	700 V	800 V	900 V	1000 V	1100 V	1200 V	1400 V	1600 V	1800 V	2100 V	2400 V
------	-------	-------	-------	--------	--------	--------	--------	--------	--------	--------	--------

COMPRESSOR

Voltage	V	400V - 3Ph - 50Hz (+10/- 10%)										
Maximum nominal current	A	140	160	182	205	218	232	266	295	356	399	443
Starting current ⁽¹⁾	A	316	334	391	414	480	494	586	615	607	720	763
Starting current with Soft Start option ⁽¹⁾	A	230	248	287	310	352	366	429	458	483	562	605

REMOTE CONTROL AUXILIARY CIRCUIT

Voltage	V	230V - 1Ph - 50Hz (+10/- 10%)										
Maximum nominal current	A	0,8	0,8	0,8	0,8	0,8	0,8	1,3	1,3	1,3	1,3	1,3
Transformer capacity	VA	160	160	160	160	160	160	250	250	250	250	250
Machine protection rating		IP 21										

(1) Starting current of largest compressor + maximum current of other compressors under full load
 Cable selection nominal current = sum of maximum nominal currents in above tables

DIMENSIONS

700 V to 1600 V models

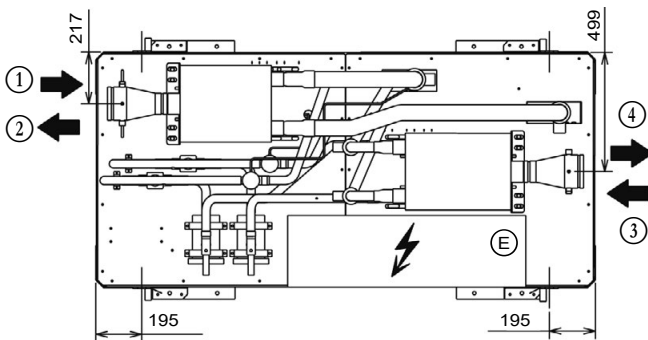
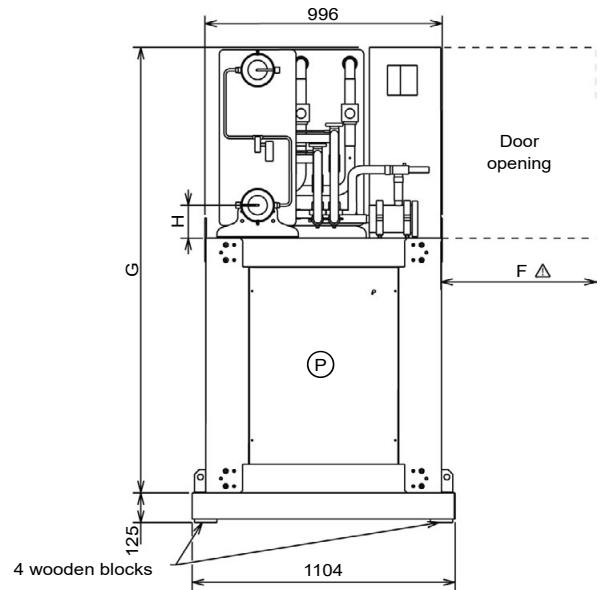
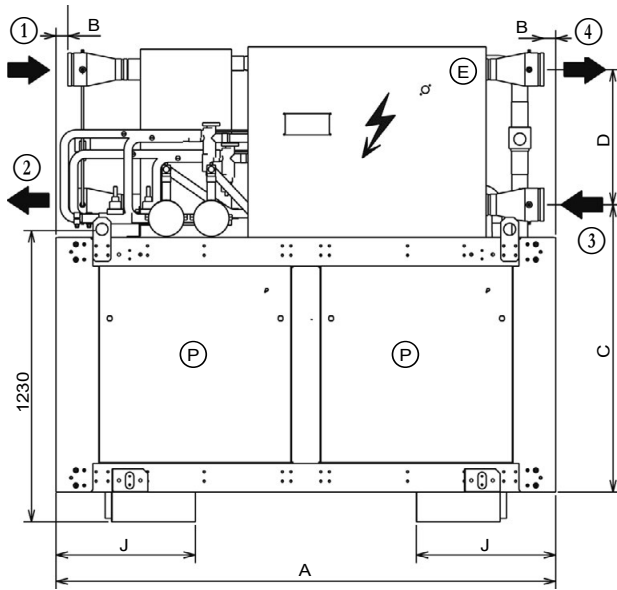

- (E) Electrical connection on the side
- (P) Noise insulation panels option

Models	Dimensions (mm)								Chilled water		Hot water		Weight (kg)	
	A	B	C	D	F	G	H	J	Inlet 1	Outlet 2	Inlet 3	Outlet 4	Empty	In operation
700 V	2099	49	1207	568	1000	1869	137	585	VICTAULIC DN 100				1044	1088
800 V	2099	49	1207	568	1000	1869	137	585					1156	1205
900 V	2099	49	1207	568	1000	1869	137	585					1189	1246
1000 V	2099	49	1207	568	1000	1869	137	585	VICTAULIC DN 125				1312	1378
1100 V	2099	49	1207	568	1000	1869	137	585					1363	1436
1200 V	2099	49	1207	568	1000	1869	137	585					1425	1510
1400 V	2499	60	1240	532	600	1887	170	715					1613	1713
1600 V	2499	60	1240	532	600	1887	170	715					1708	1818

DIMENSIONS

1800 V to 2400 V models

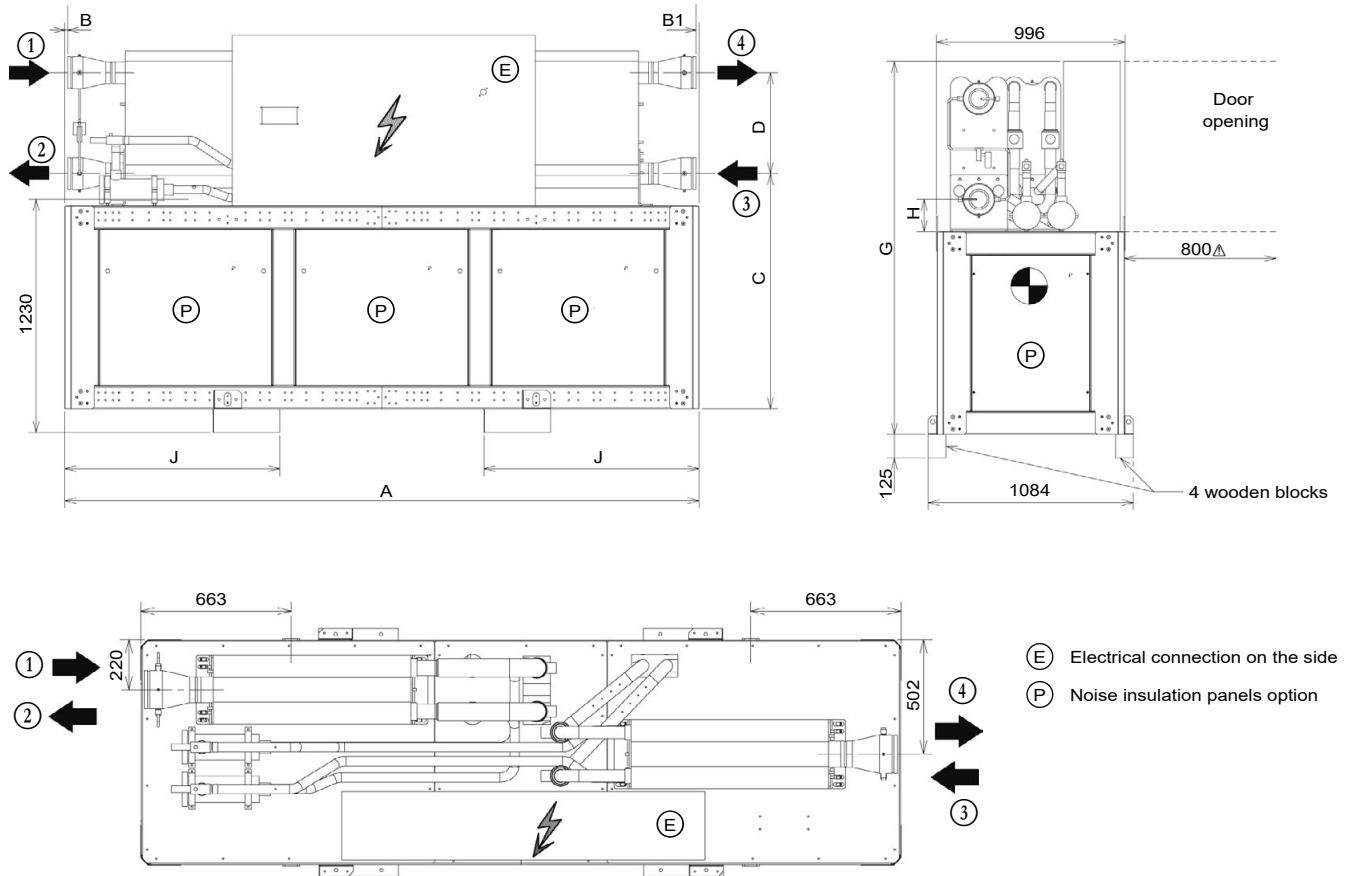

Models	Dimensions (mm)								Chilled water		Hot water		Weight (kg)	
	A	B	B1	C	D	G	H	J	Inlet 1	Outlet 2	Inlet 1	Outlet 2	Empty	In operation
1800 V	3350	63	63	1240	532	1970	170	1135	VICTAULIC DN 150				2284	2472
2100 V	3350	15	15	1240	532	1970	170	1135					2376	2588
2400 V	3350	15	15	1240	532	1970	170	1135					2418	2637